



Installation instructions

📍 10087 ST

Subaru Impreza WRX / STI
6-Gang-Getriebe

STREET VERSION
with two-piece shifter housing for
vehicles with interior equipment



PLEASE NOTE

SAFETY FIRST!

- ⚠ Please only do the installation if you have appropriate experience in the automotive sector and have the right tools! An incorrectly installed Shifter can seriously damage the transmission or make the vehicle undriveable or not shiftable and lead to serious accidents!
- ⚠ If work on the electrical system is necessary, please follow the manufacturer's specifications.
- ⚠ It is essential to leave the ignition switched off when the plugs are disconnected.
Do not leave the car key in the vehicle.
- ⚠ Carry out all work with care and cleanliness! For the professional assembly of a shifter is no force required. All parts are designed to fit your vehicle.
- ⚠ If you are unsure, please contact your trusted workshop about the installation!

BASICALLY

- ⚠ Use ethyl alcohol/brake cleaner to clean all aluminum parts.
- ⚠ Occasionally lubricate all moving parts with spray grease, which has good creeping properties.
Our recommendation: Würth HHS 2000 (WD-40 or similar is unsuitable because it is too thin)
- ⚠ All screws and nuts that are not self-locking or are fitted with tooth lock washers glue in during assembly!
- ⚠ Never kink shift cables, please!

i SURFACES AND THEIR CARE

Please note that an untreated aluminum surface (ALU) is sensitive to aggressive Liquids to which i.a. Hand sweat also counts. Especially the high-strength 7075 aluminum we use has a tendency to form black spots of corrosion due to its high copper content. Under special circumstances, very salty air near the sea and coast can lead to corrosion. The surfaces should therefore be cleaned regularly and treated with care to prevent this. For this purpose, e.g. ethyl alcohol or brake cleaner. Only spray these onto a cloth and wipe the shifter with it, NEVER spray the shifter directly. If stains have already formed, they can be removed with commercially available aluminum polish, but that is also not allowed get into the movable parts of the shifter. The anodized versions of our shifters (EXS, EXGR) are more resistant to corrosion. The steel parts have to be also cared in all variants.

TIPS FOR GEAR SHIFTING

i FORCE DOESN'T MAKES YOU FASTER – IT ONLY HARMS THE TRANSMISSION

The question arises again and again: "Does a CAE shifter puts more strain on a gearbox than a standard gear lever?" The answer is clear: "No!" The things that are most stressful for a synchronizer ring in a transmission are excessive shifting forces or a wrong shift in gear. Basically, the shift travel with a CAE Shifter is significantly shorter than with the standard lever. We achieve 30 - 55 % reduction depending on the vehicle and transmission type. This can only be achieved by using the appropriate gear ratio on the shift lever. You can feel it through the precision of a CAE shifter engaging the gears is much better than with a standard gear lever designed for comfort. The force for this decreases in the same proportion - we put in the gears with significantly less load for the synchronizer rings. In addition, with a correctly adjusted CAE shifter put in the gears is very precise and shifting into the wrong gear is extremely rare. Even in motorsport, fast, precise, but still sensitive shifting leads to the goal! Everything else is pure tugging and tearing which puts a disproportionately high strain on a transmission and in the worst case causes a fatal wrong shift in gear!

- i** The shifter is designed for vehicles with interior equipment. The center console does not need to be removed for installation. The center console does not need to be machined, only the original bellows can not be mounted.
- i** We recommend gluing in all nuts or screws during installation! Lubricate the pilot pin and all moving parts occasionally with good spray grease, our recommendation: Würth HHS 2000. To do this, lift the rubber caps on the ball heads, for example. For cleaning the aluminum parts we recommend brake cleaner.

The removal

- ▶ Pull off the shift bag and remove it together with the shift knob from the shift lever.
 - ▶ Remove the cover frame of the center console.
 - ▶ Unscrew rubber sleeve with retaining frame.
- i** Now lift the vehicle safely on a car lift and remove the underbody paneling.
- ▶ Completely remove the original gearshift. First remove the large rubber bearing of the gearshift support on the transmission, then remove the holder from the transmission. (Picture 1, 2, 3, 4)
 - ▶ Drive the double split pin from the shift rod adapter on the transmission shift shaft upwards, unscrew the reverse gear release and unthread the complete gearshift from the rear bearing and remove it upwards.
 - ▶ Dismantle the gearshift so that the rubber sleeve is separate, this will be used further.



Modification rubber sleeve

- ▶ Widen the holes for the 4 fixing screws of the shifter with a 12 mm punch; here the spacers will be inserted later.
- ▶ Fix the cover plugs in the rubber with the supplied cable ties.
- ▶ Insert the shifter rod into the bellows of the boot and pull the collar of the bellows onto the metal washer of the shifter rod.



The pilot pin

ⓘ GREASE THE PILOT PIN AND THE FITTING HOLE WELL BEFORE ASSEMBLY.

- ▶ Make sure that neither the bore nor the bolt are damaged.
- ▶ The photos (Picture 6,7) illustrate the principle of the rotating pilot pin. The fixing screw engages in the groove of the pilot pin and secures it vertically.
- ▶ Slightly tighten the locating screw with the toothed lock washer and secure it with the wire supplied.

ⓘ The pilot pin must remain rotatable!



ⓘ Regularly spray creeping oil into the collar at the tip of the pilot pin. This is absolutely necessary for proper functioning. Remove excess grease and keep surfaces clean. NEVER spray cleaner or degreaser into the connection. This applies to all bearing points of the shifter.



Installation CAE Shifter

▶ Installation CAE Shifter

- ▶ First, mount only the base frame of the shifter on the tunnel with the supplied M6x16 screws, make sure the rubber pins are correctly seated in the shifter base plate.
- ▶ The center console is mounted only after the shifter has been completely adjusted. For this, the shifter upper part must be removed again.
- ▶ Grease the pilot pin of the shifter rod well, as well as the fitting hole in the shifter rod fork on the shifter lever.
- ▶ Loosen the spring stop in the shifter so that it can move but does not rattle or fall off (for further information, see Adjusting the shifting travel).
- ▶ Now place the complete upper part of the shifter on the lower part, inserting the bolt of the shift rod into the fitting hole.

ⓘ Grease the bolt well and do not tilt it!

- ▶ Fasten the upper part of the shifter to the lower part using the 4 M5 x 12 ribbed screws (the screws produce slight chips with their ribbed heads when tightened, this is normal).
- ▶ Immediately screw the locking screw for the shift rod into the fork, this must later be additionally secured with wire.
Tighten the screw only until the tooth lock washer is on block.
- ▶ Attach the reverse gear disengagement to the gear-box:
The fixed screw in the connector is inserted into the housing bore and this is screwed to the lever.

ⓘ PLEASE NOTE: This disables the standard reverse gear lockout. The adjustment of the CAE RW lock is therefore essential.



Adjusting shifting travel of the 6-speed transmission

▶ Shift the gearbox to 3rd or 4th gear by hand. This is the "middle position" of the gearbox. To do this, move the shift lever forwards or backwards without rotating it.

▶ Now tighten the spring stop again.

ⓘ CHECK: When 3rd / 4th gear is engaged, the lateral play on the shift lever must be the same on both sides, otherwise readjust the spring stop.

▶ Now use the shift lever to engage 1 / 2 gear (search) and screw in the stop screw until the gears can be changed cleanly in level 1 / 2. The screw must not touch the bolt when the gear is engaged. (approx. 0.3 mm clearance is ok.)

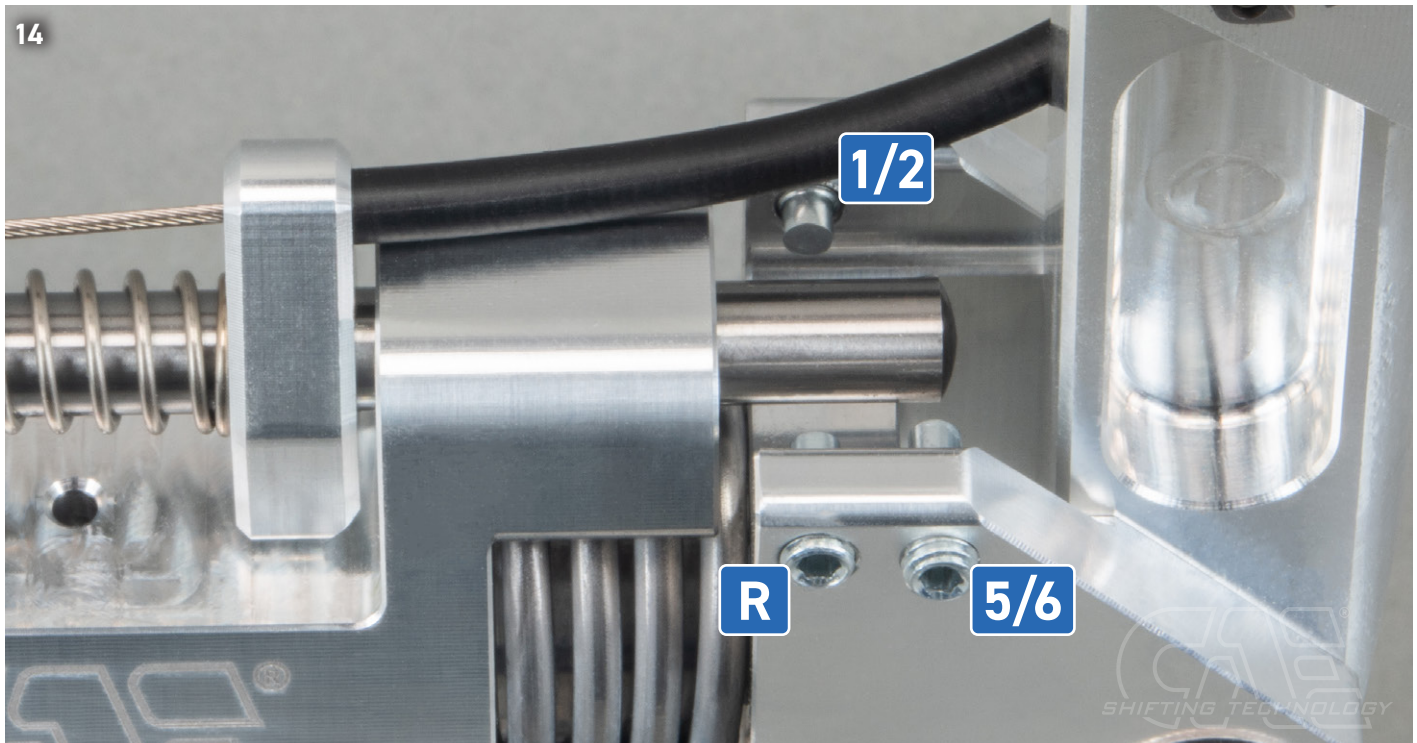
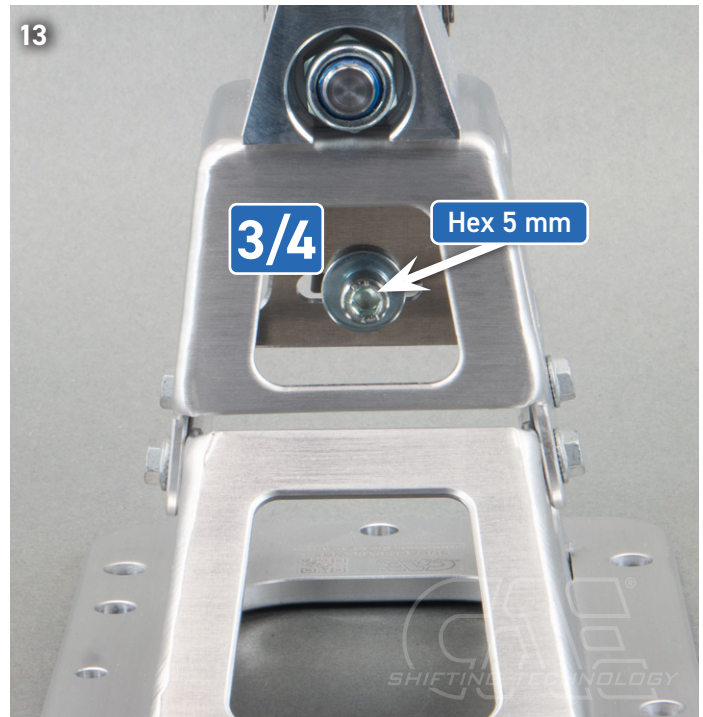

▶ Shift gearbox to 5th/6th gear level and screw in stop screw until these gears can also be shifted cleanly. The screw must not touch the bolt when the gear is engaged. (approx. 0.3 mm clearance) is ok.

▶ Operate reverse gear lock via the mechanism on the shift lever and shift the transmission into reverse gear. (Lever to the right) Screw in the stop screw until reverse gear can be engaged cleanly. The screw must not touch the bolt when the gear is engaged. (approx. 0.3 mm clearance is ok)

▶ Reassemble the bellows frame, we recommend double sided tape.

▶ Now loosen the 4 rib screws of the shifter upper part and the locking screw in the pilot bolt again and remove the upper part.

▶ Then install the center console completely.

▶ Then put the shifter upper part back on and screw it tight.

▶ Then secure the locking screw with binding wire.

- i** If there are strong rattling noises when driving, we recommend the following:
Wrap the universal joint to the gearbox tightly with selffusing rubber tape.

15



FINALLY! Check all functions and settings during the test drive and readjust if necessary!

Incorrect or inaccurate settings can cause damage to the gear box and consequential damage!

If you have any questions or problems, please be sure to contact us, we look forward to your feedback to improve our products.



RACE THE ORIGINAL



Alte Bottroper Strasse 103
D-45356 Essen
0049. 201. 8 777 802
service@cae-racing.de

WWW.CAE-RACING.DE