

📍 10025 J

Opel Astra J
M40 6-speed transmission

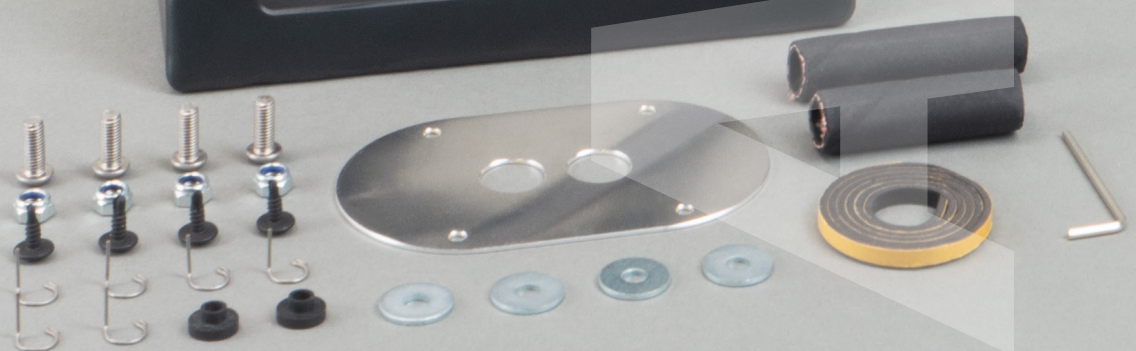

WWW.CAE-RACING.DE



PLEASE NOTE

SAFETY FIRST!

- 📍 Raise the vehicle safely with a vehicle lift for installation. Improper lifting can cause damage to the vehicle and/or personal injury or even death!
- 📍 Please only do the installation if you have appropriate experience in the automotive sector and have the right tools! An incorrectly installed Shifter can seriously damage the transmission or make the vehicle undriveable or not shiftable and lead to serious accidents!
- 📍 If work on the electrical system is necessary, please follow the manufacturer's specifications.
- 📍 Carry out all work with care and cleanliness! For the professional assembly of a shifter is no force required. All parts are designed to fit your vehicle.
- 📍 If you are unsure, please contact your trusted workshop about the installation!

BASICALLY

- 📍 Use ethyl alcohol/brake cleaner to clean all aluminum parts.
- 📍 Occasionally lubricate all moving parts with spray grease, which has good creeping properties. Our recommendation: Würth HHS 2000 (WD-40 or similar is unsuitable because it is too thin)
- 📍 All screws and nuts that are not self-locking or are fitted with tooth lock washers glue in during assembly!
- 📍 Never kink shift cables, please!

i SURFACES AND THEIR CARE

Please note that an untreated aluminum surface (ALU) is sensitive to aggressive Liquids to which i.a. Hand sweat also counts. Especially the high-strength 7075 aluminum we use has a tendency to form black spots of corrosion due to its high copper content. Under special circumstances, very salty air near the sea and coast can lead to corrosion. The surfaces should therefore be cleaned regularly and treated with care to prevent this. For this purpose, e.g. ethyl alcohol or brake cleaner. Only spray these onto a cloth and wipe the shifter with it, NEVER spray the shifter directly. If stains have already formed, they can be removed with commercially available aluminum polish, but that is also not allowed get into the movable parts of the shifter. The anodized versions of our shifters (EXS, EXGR) are more resistant to corrosion. The steel parts have to be also cared in all variants.

TIPS FOR GEAR SHIFTING

i FORCE DOESN'T MAKES YOU FASTER - IT ONLY HARMS THE TRANSMISSION

The question arises again and again: "Does a CAE shifter puts more strain on a gearbox than a standard gear lever?" The answer is clear: "No!" The things that are most stressful for a synchronizer ring in a transmission are excessive shifting forces or a wrong shift in gear. Basically, the shift travel with a CAE Shifter is significantly shorter than with the standard lever. We achieve 30 - 55 % reduction depending on the vehicle and transmission type. This can only be achieved by using the appropriate gear ratio on the shift lever. You can feel it through the precision of a CAE shifter engaging the gears is much better than with a standard gear lever designed for comfort. The force for this decreases in the same proportion - we put in the gears with significantly less load for the synchronizer rings. In addition, with a correctly adjusted CAE shifter put in the gears is very precise and shifting into the wrong gear is extremely rare. Even in motorsport, fast, precise, but still sensitive shifting leads to the goal! Everything else is pure tugging and tearing, which looks "important", but in no way makes it faster - but it puts a disproportionately high strain on a transmission and in the worst case causes a fatal wrong shift in gear!

Included in delivery

- ▶ 1x shifter completely assembled, design depending on ordered variant (Picture A)
 - ❗ **The coupling rod on the side of the shifter is removed for transport and is located in the accessories bag.**
- ▶ 1x Shift knob incl. counter screw M6x20 V2A, design depending on ordered variant (Picture B)
- ▶ Accessories package (Picture C)
- ▶ 1x shift cable (S), 1x selector cable (W) (Picture D, E)

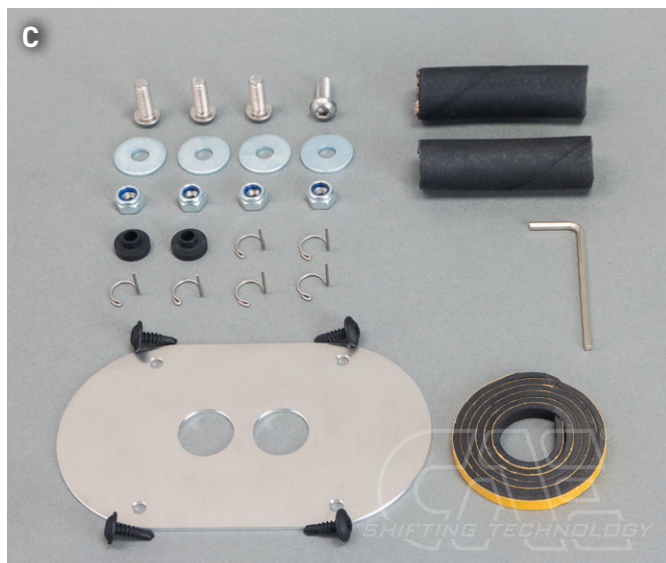

- i** The shifter is intended for vehicles without interior equipment. The center console must be removed or cut out until a corresponding clearance is ensured.
- i** The shifter should be screwed directly onto the sheet metal of the center tunnel, any existing carpet must be cut out.
- i** Glue in all nuts / screws during assembly! Never kink shift cables! Lubricate all moving parts occasionally with good spray grease. For cleaning the aluminum parts we recommend commercial spiritus.

The removal

- ▶ Remove the original shift lever and shift cables.
- ▶ Remove the transmission shift lever.

Reworking the gearbox shift lever

- ▶ Cut off the absorber weight of the gearshift lever. (Picture 1, 2)
- ▶ Put rubber sleeves on the ball necks.



Prepare the shift cables

- ▶ On the shifter side, remove the ball cups and the first SW24 nut and washer / lock washer from each of the cables.

Laying the switching cables

- ▶ Placement of switching cables (Picture 3)

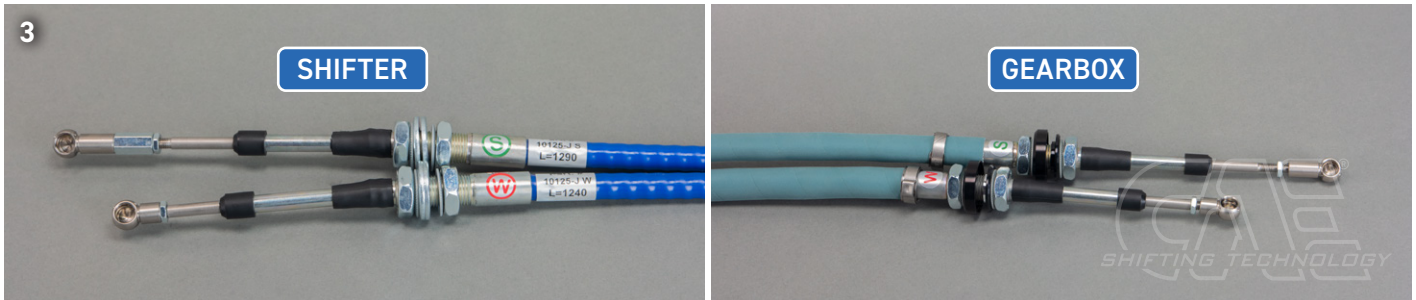

- ▶ Pay attention to the assignment of the ropes.

S **W** the stickers with border belong to the shifter, **S** **W** the stickers without border belong to the gearbox.

- ▶ Now insert the shift cables from the interior through the original hole in the bulkhead and guide them towards the transmission cable holder. At the same time, attach the supplied cover plate and the black protective hoses to the cables. (Picture 4, 5)

i We recommend brake cleaner as a lubricant for the rubber parts, as this evaporates without leaving any residue.

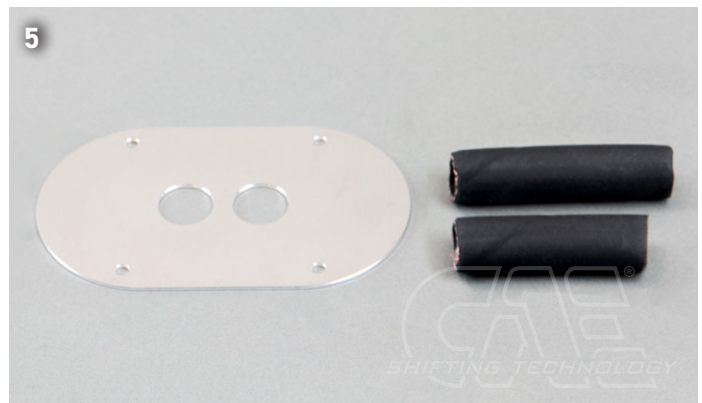

Installation CAE Shifter

- ▶ Mount the shifter tower on the center tunnel using the Allen screws provided. Thread the cables into the holes in the front plate of the tower. It is essential to ensure that the ropes (W) / (S) are correctly assigned and that the washers and lock washers are positioned correctly.

- ▶ The M16 threads must protrude as far as possible from the shifter housing, no thread is visible inside. Use the toothed lock washers inside and outside to secure, do not glue the nuts !!!

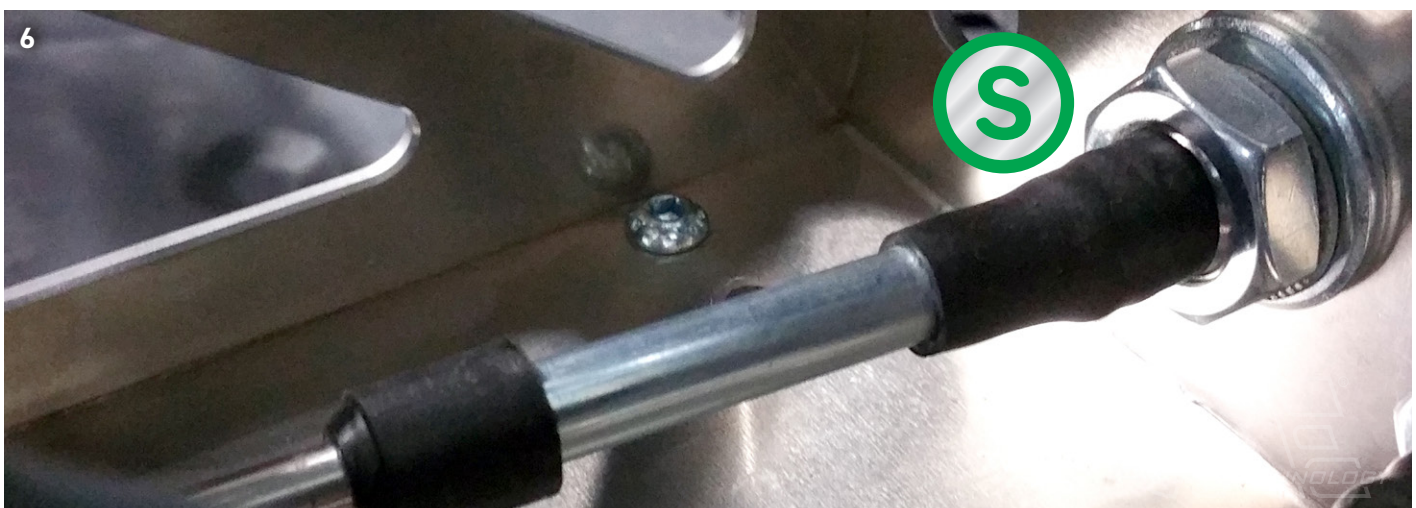

- ▶ Then screw on the ball heads and press them onto the shift lever.

Mounting the shift cables on the transmission

- ▶ Assemble the shift cables with washers and nuts as shown in the picture. (Picture 7)
- ▶ The collar of the aluminum washer engages over the lug on the back of the gear cable holder and prevents it from slipping off the holder. Mount the respective centering disks from the front.

i **ATTENTION! The centering disks have different diameters!**

- ▶ Now reassemble the lightened transmission shift lever as well as the selector lever and screw the ball cups onto the cable ends and press on the ball heads. Grease the ball cups beforehand.

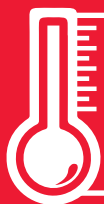
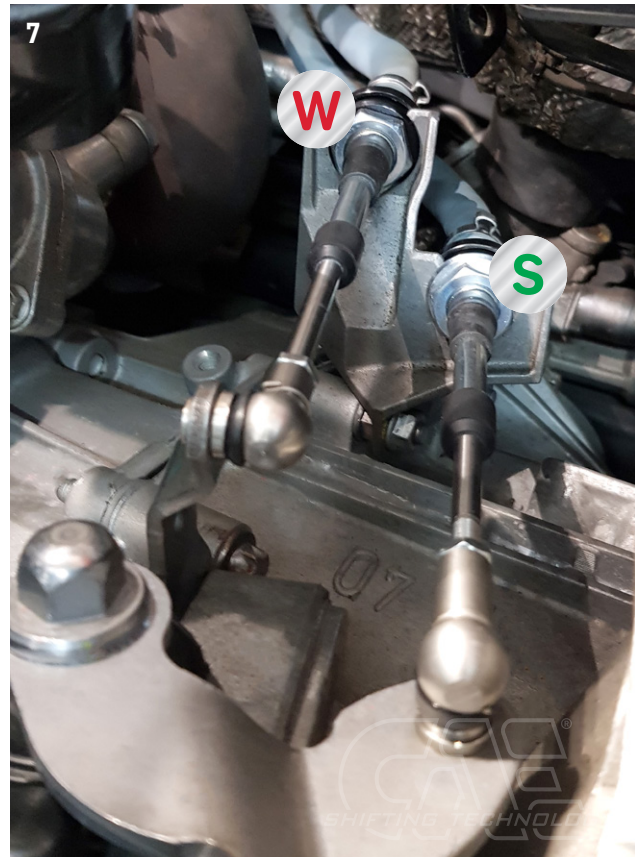

HEAT PROTECTION FOR SHIFT CABLES (FOR ALL VEHICLES WITH CAE SHIFT CABLES)

Exhaust systems generate incredible temperatures, which can be several 100 degrees, especially under full load! Therefore, the shift cables must be absolutely protected with the blue-gray protective hoses against the strong heat effect!

Also the protected shift cables must not be in contact with the exhaust. For turbo engines please take additional measures should be taken, e.g. aluminum honeycomb sheets, heat protection tape or foils.



**EXCESSIVELY HIGH TEMPERATURES PERMANENTLY DAMAGE THE SHIFT CABLES!
ESPECIALLY IN MOTORSPORTS, THE HEAT DEVELOPMENT IS ENORMOUS!**

CHECK THE END POSITIONS OF THE SWITCHING CABLES

❗ PLEASE NOTE: ! Check cables for "end position free travel". When a gear is engaged, there must still be a residual travel available on the cable! (Picture A, B, C)

Sample pictures:

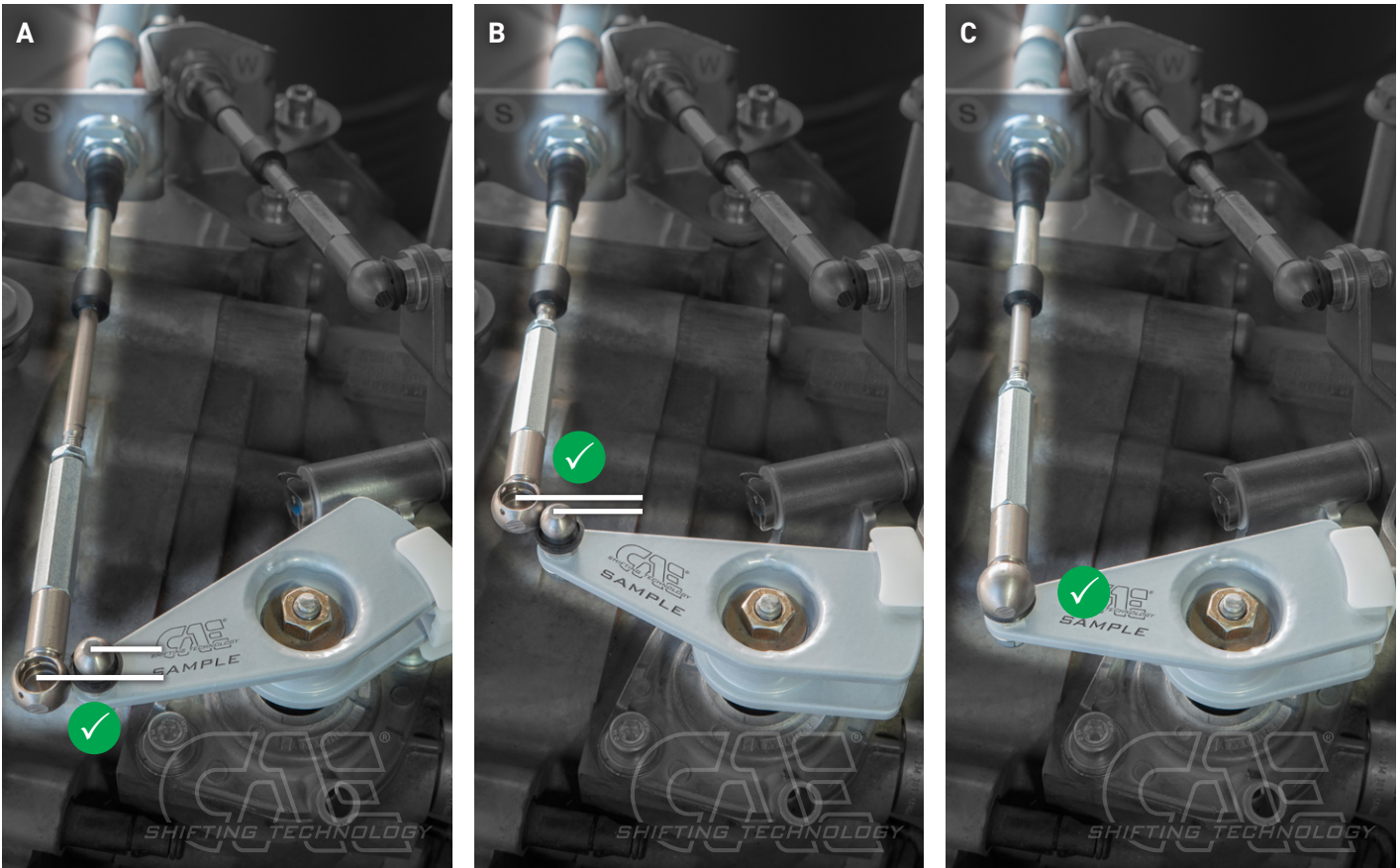

❗ CHECK: CHECK: With the gear engaged, pull the ball cup off the gearshift lever and check whether the shift cable **S** can still be moved at least 3 mm. This applies to the "front" gears R-1-3-5 (Picture A) with the cable retracted and to the "rear" gears 2-4 (6) (Picture B) with the cable extended. The end position can be corrected by screwing the ball cups on the M6 thread of the cables in or out.

► After checking and adjusting, reassemble the ball cups from the shift cable. (Picture C)

ATTENTION: THIS CONTROL IS VERY IMPORTANT FOR THE FUNCTION OF THE SHIFTER !!!
If the remaining travel on the shift cable is missing, there is an immediate risk of damage to the gearbox. !!!!

Adjust the shift range 6 speed gearbox

i If mounted, pull off the side coupling rod on the shifter. (will be adjusted later) (Picture 8)

i Synchronize center position of shifter with transmission:

- ▶ Loosen the spring stop (Allen key 5mm) (Picture 9).
- ▶ The shift lever should be slightly tilted to the right in position 3/4. (Knob is approx. 1.5cm to the right, lower end of the shift lever to the left) This setting can be adjusted in the shifter housing.
- ▶ Now adjust the coupling rod (R/L THREAD) so that the selector cable fits EXACTLY on the ball pin.

i Check: With 3rd/4th gear engaged, the lateral play on the shift lever must be the same, otherwise readjust with the coupling rod.

- ▶ Now move the shift lever to the 1st - 2nd gear level (search) and adjust the stop screw so that 1st and 2nd gear can be changed without problems (Picture 10).
- ▶ Move the gearbox to the 5th/6th gear level using the shift lever (SEARCH) and screw in the stop screw until the 5th gear can be engaged cleanly. (Picture 10)
- ▶ Actuate locking pin via cable and shift gearbox to reverse gear level. Screw in stop screw until reverse gear can be engaged cleanly. (Picture 10)

i The adjusting screws are deliberately difficult to turn in order to prevent unintentional adjustment. It is essential to use a high-quality 2.5 mm Allen key.

- ▶ This completes the basic adjustment.
- ▶ If the shift lever hits the side of the shifter housing (R or 6th gear), the center position must be readjusted accordingly (step 3).

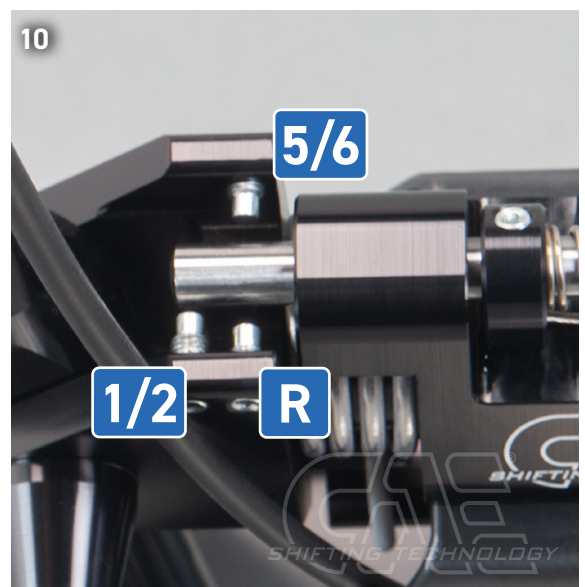
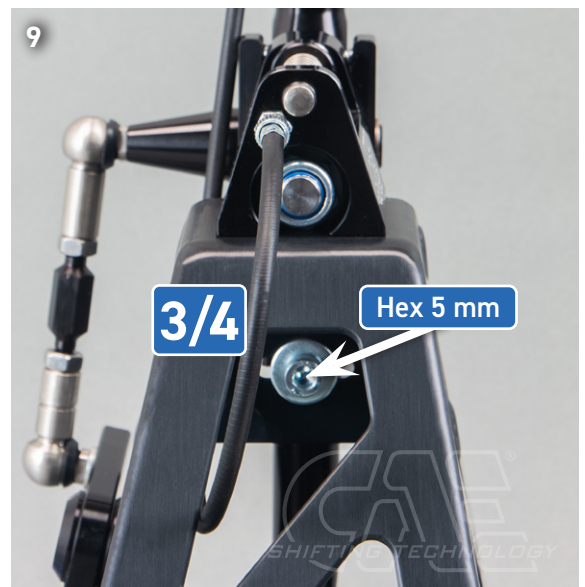
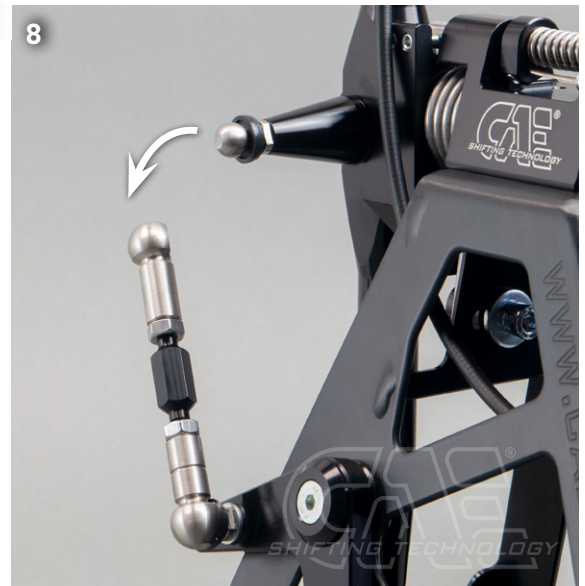



FINALLY! Check all functions and settings during the test drive and readjust if necessary!

Incorrect or inaccurate settings can cause damage to the gear box and consequential damage!

If you have any questions or problems, please be sure to contact us, we look forward to your feedback to improve our products.



RACE THE
ORIGINAL



Alte Bottroper Strasse 103
D-45356 Essen
0049. 201. 8 777 802
service@cae-racing.de

WWW.CAE-RACING.DE