



# ULTRA SHIFTER

## Installation instructions

📍 10069

Mazda MX5 ND  
6-speed gearbox



WWW.CAE-RACING.DE



# PLEASE NOTE

## SAFETY FIRST!

- 📍 Raise the vehicle safely with a vehicle lift for installation. Improper lifting can cause damage to the vehicle and/or personal injury or even death!
- 📍 Please only do the installation if you have appropriate experience in the automotive sector and have the right tools! An incorrectly installed Shifter can seriously damage the transmission or make the vehicle undriveable or not shiftable and lead to serious accidents!
- 📍 If work on the electrical system is necessary, please follow the manufacturer's specifications.
- 📍 Carry out all work with care and cleanliness! For the professional assembly of a shifter is no force required. All parts are designed to fit your vehicle.
- 📍 If you are unsure, please contact your trusted workshop about the installation!

## BASICALLY

- 📍 Use ethyl alcohol/brake cleaner to clean all aluminum parts.
- 📍 Occasionally lubricate all moving parts with spray grease, which has good creeping properties. Our recommendation: Würth HHS 2000 (WD-40 or similar is unsuitable because it is too thin)
- 📍 All screws and nuts that are not self-locking or are fitted with tooth lock washers glue in during assembly!
- 📍 Never kink shift cables, please!

## **i** SURFACES AND THEIR CARE

Please note that an untreated aluminum surface (ALU) is sensitive to aggressive Liquids to which i.a. Hand sweat also counts. Especially the high-strength 7075 aluminum we use has a tendency to form black spots of corrosion due to its high copper content. Under special circumstances, very salty air near the sea and coast can lead to corrosion. The surfaces should therefore be cleaned regularly and treated with care to prevent this. For this purpose, e.g. ethyl alcohol or brake cleaner. Only spray these onto a cloth and wipe the shifter with it, NEVER spray the shifter directly. If stains have already formed, they can be removed with commercially available aluminum polish, but that is also not allowed get into the movable parts of the shifter. The anodized versions of our shifters (EXS, EXGR) are more resistant to corrosion. The steel parts have to be also cared in all variants.

## TIPS FOR GEAR SHIFTING

### **i** FORCE DOESN'T MAKES YOU FASTER - IT ONLY HARMS THE TRANSMISSION

The question arises again and again: "Does a CAE shifter puts more strain on a gearbox than a standard gear lever?" The answer is clear: "No!" The things that are most stressful for a synchronizer ring in a transmission are excessive shifting forces or a wrong shift in gear. Basically, the shift travel with a CAE Shifter is significantly shorter than with the standard lever. We achieve 30 - 55 % reduction depending on the vehicle and transmission type. This can only be achieved by using the appropriate gear ratio on the shift lever. You can feel it through the precision of a CAE shifter engaging the gears is much better than with a standard gear lever designed for comfort. The force for this decreases in the same proportion - we put in the gears with significantly less load for the synchronizer rings. In addition, with a correctly adjusted CAE shifter put in the gears is very precise and shifting into the wrong gear is extremely rare. Even in motorsport, fast, precise, but still sensitive shifting leads to the goal! Everything else is pure tugging and tearing, which looks "important", but in no way makes it faster - but it puts a disproportionately high strain on a transmission and in the worst case causes a fatal wrong shift in gear!

## Included in delivery

- ▶ 1x shifter (The shifter is pre-assembled for shipping with 2 screws from the accessories package).  
Design depending on ordered variant (Picture A)
- ▶ 1x Shift knob incl. counter screw M6x20 V2A,  
Design depending on ordered variant (Picture B)
- ▶ Accessories package (Bild C)
- ▶ Kragenblech & Halter für Mittelkonsole (Bild D)

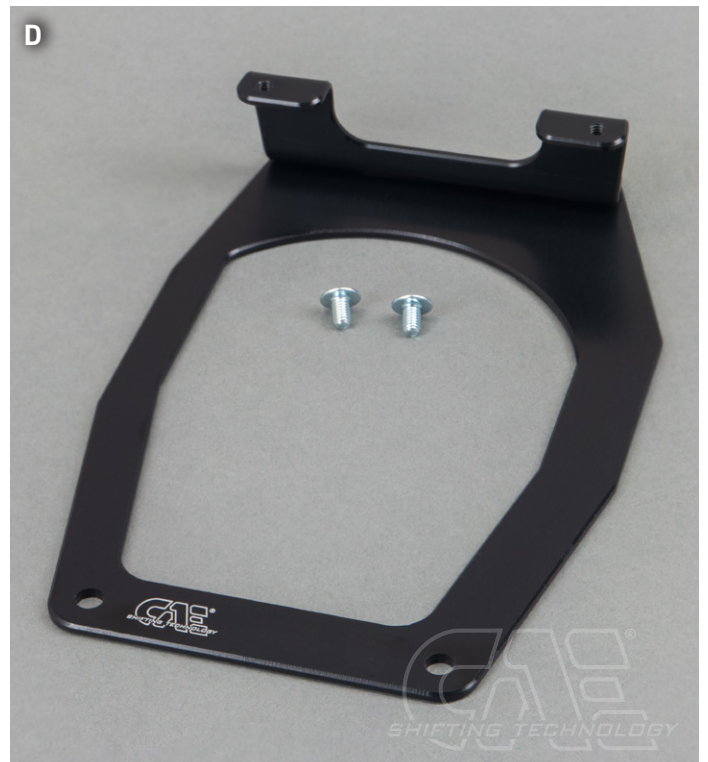



- i** The shifter is designed for vehicles with interior equipment. The center console must be cut out until proper clearance is ensured.
- i** Lubricate all moving parts occasionally with good spray grease. For cleaning the aluminum parts we recommend commercial spirit.
- i** Due to the racing design of all components and the 100% backlash-free construction, the shifter transmits vibrations at high speeds. This is due to design and does not represent a defect. Please note this before assembly. Already installed components are not taken back by CAE.

### The removal

- ▶ Remove center console completely.
- ▶ Remove original shift boot.
- ▶ Remove original gearshift lever and housing. (the housing is glued with sealing compound at the factory).
- ▶ Clean and degrease flange surface

### The installation

- ▶ Apply a thin layer of the green sealing compound supplied to the sealing surface on the gear unit. (Picture 1)
- ▶ Place a toothed lock washer under each of the Allen screws.
- ▶ Tighten all 4 fastening screws. (Picture 2)
- ▶ Now install the lower transmission tunnel boot. Turn the original lower boot over and install with the actual top side down, carefully pulling the boot over the neck of the shifter foot. (Picture 3)

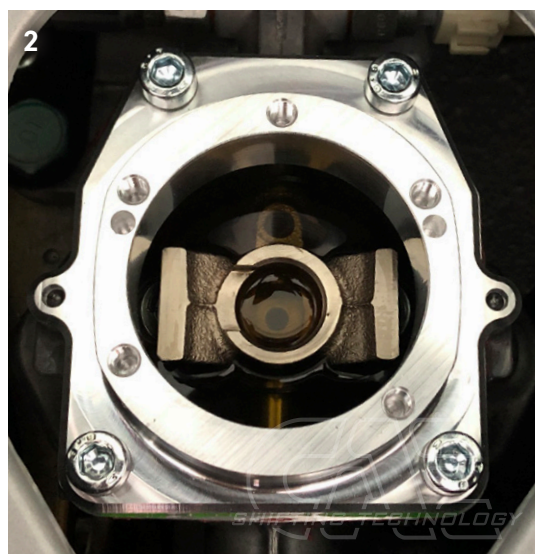
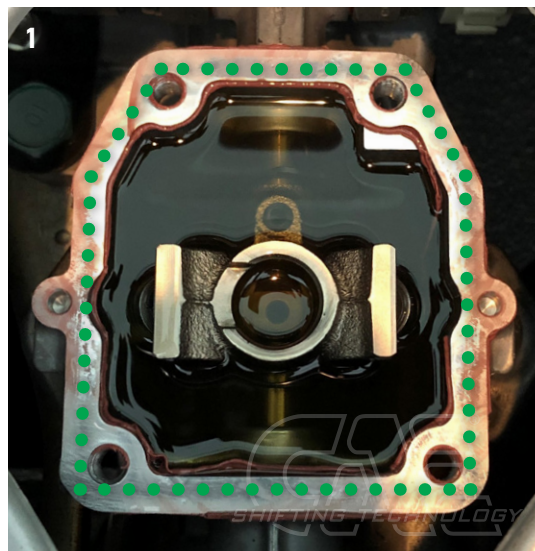

- ▶ Now modify if necessary the upper gearbox tunnel boot and mount it.
- ▶ The original upper boot with sheet metal frame is (for deliveries from 08/2021) is no longer required. (Picture 4)
- ▶ For earlier deliveries, the boot must be modified. (Picture 4a)





- ▶ The rubber sleeve is fixed to the front bolts with the supplied aluminum frame and the bracket for the center console is screwed on (Picture 5, 6)
- ▶ Make sure that the lower sleeve is properly seated. The frame must press the sleeve firmly onto the transmission tunnel so that it is tight.
- ▶ Now apply a thin layer of the supplied green sealant to the upper sealing the upper sealing surface of the shifter foot. (Picture 6)
- ▶ Apply a little gear oil to the ball on the lower part of the gearshift lever and fit the upper part of the shifter from above. Hold the shift lever vertically and carefully insert the ball into the gearbox.
- ▶ Now tighten the upper part of the shifter with the 5 M6 Allen screws. (12NM) (Picture 7, 8)



**i** Place a toothed lock washer under each of the screw heads of the M6 Allen screws.

**i PLEASE NOTE:** There must be a gap of approx. 4-5 mm between the shifter and the gearbox tunnel / collar plate. (Picture 8) If there is not enough space, loosen the 3 connecting screws of the PPF carrier on the gearbox and lift the gearbox a little. Then tighten the screws again and check if there is enough space between shifter and gearbox tunnel.

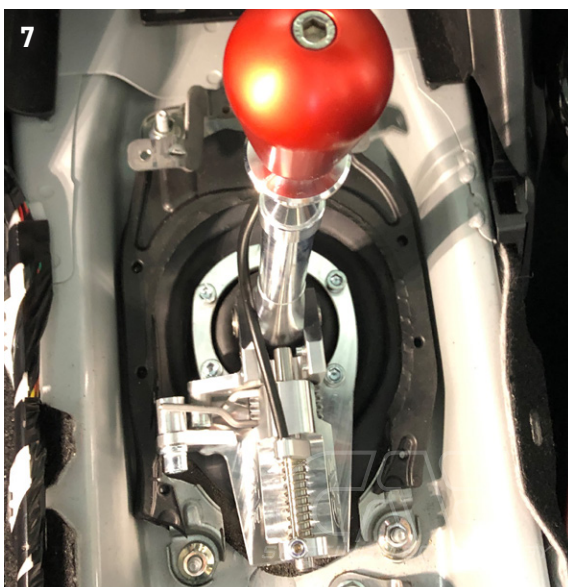

**i** Generally grease every bearing position regularly. We recommend Würth HHS 2000. Secure all nuts / screws with toothed lock washer or glue them in place during assembly!

## Adjusting the shifting range of the 6-speed gearbox

- ▶ Adjust center position Pos 3/4
- ▶ Loosen spring stop (Allen key 5mm) (Picture 9)
- ▶ Shift gearbox to 3rd or 4th gear. The 3rd and 4th gear is in neutral zero position. To engage them, simply move shift lever forward or backward without load.
- ▶ Tighten spring stop again

**ⓘ CHECK:** When 3rd and 4th gear are engaged, the lateral play on the shift lever must be the same. If this is not the case, the spring stop must be readjusted. (0.5 mm is already a lot here). This is the basic setting of the shifter and must be carried out very precisely.

- ▶ Then shift the gearbox to level 1 / 2 using the shift lever and adjust the stop screw until the gears in level (1/2) can be changed cleanly. The adjusting screw should have a clearance of approx. 0.5 mm. (Picture 10)
- ▶ Now shift gearbox to (5/6) gear level using shift lever and screw in stop screw until 5th gear can be engaged cleanly. Screw has approx. 0.5 mm clearance (Picture 10).
- ▶ Actuate reverse gear lock pin via pull and shift transmission to reverse gear level. (R) Screw in corresponding stop screw until it has approx. 0.5 mm clearance. (Picture 10)

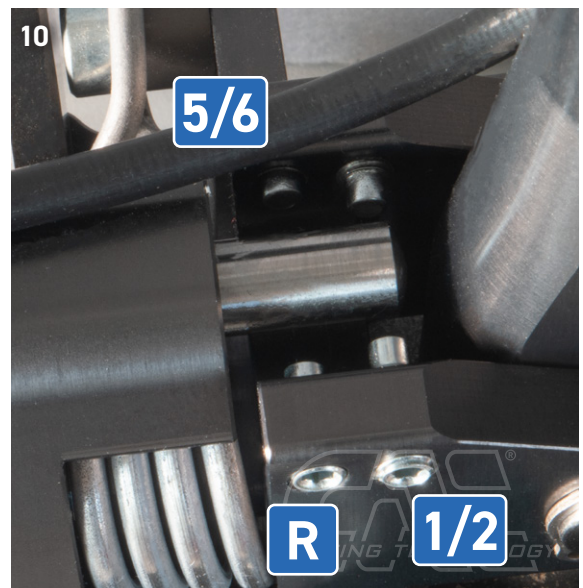
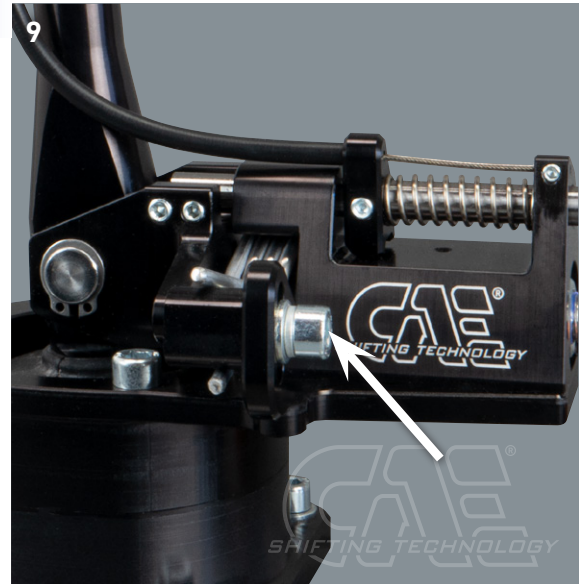

**FINALLY!** Check all functions and settings during the test drive and readjust if necessary!

**Incorrect or inaccurate settings can cause damage to the gear box and consequential damage!**



## Machining of the center console

- ▶ Process the center console according to the following pictures so that it can be mounted above the shifter:
- ▶ Cut out center console connector bar in shifter unit area. (red marked area)  
(Picture 11, 12)

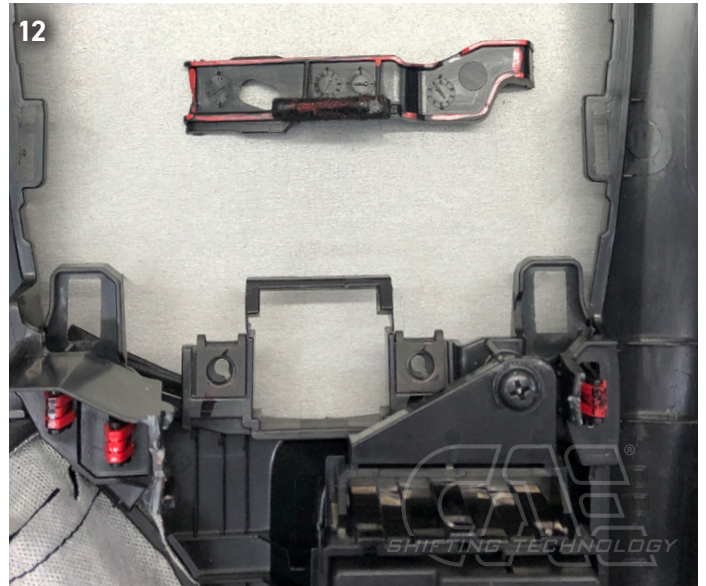
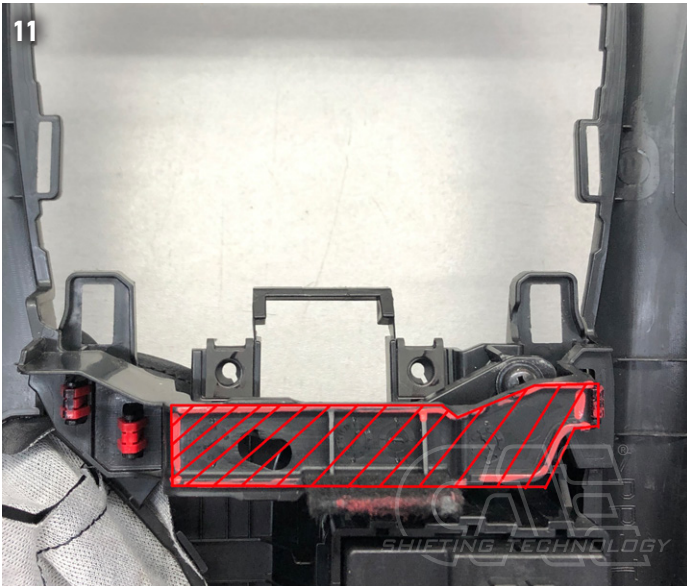

- ▶ Mill out the switch unit of the center console in the area marked in red. (Picture 13, 14)

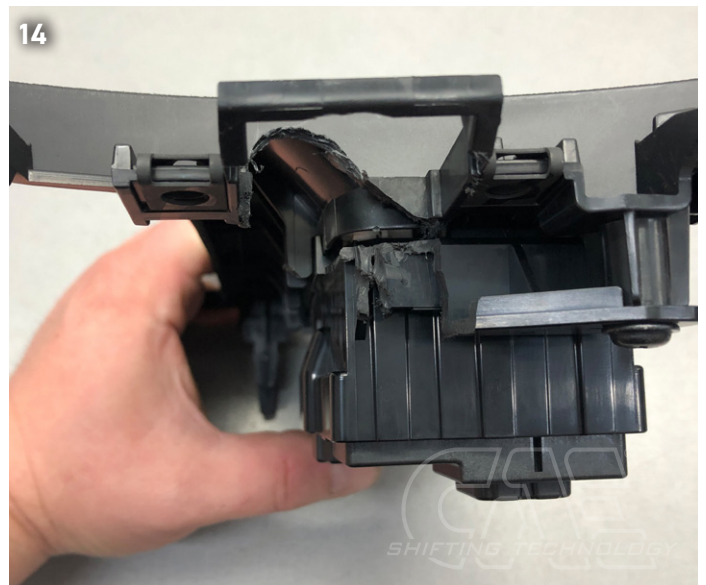
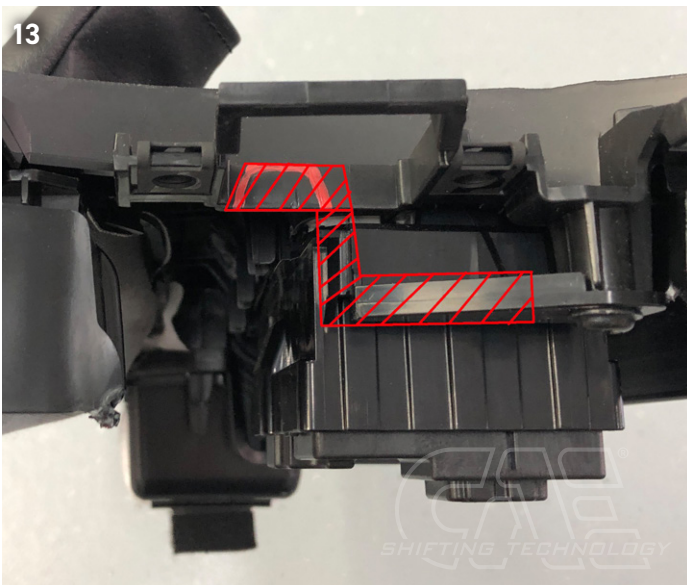



**i** The shifter must have enough space to the fairing, as it moves with the transmission. (Picture 15, 16)

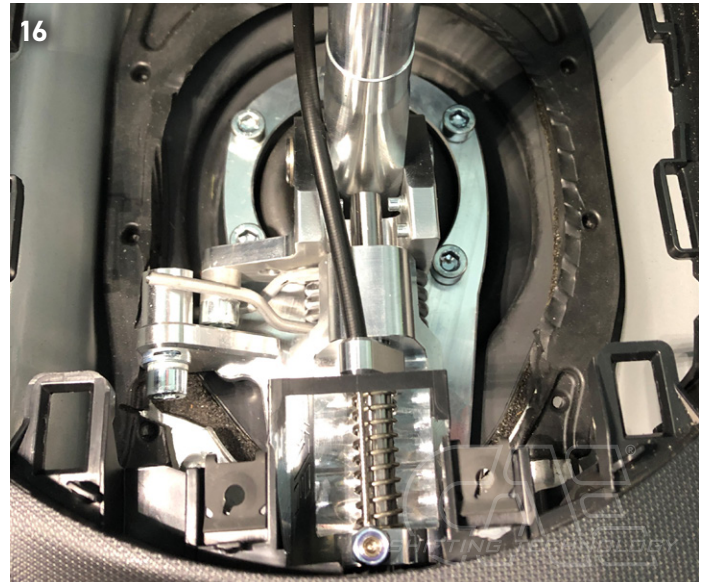

► Now reinstall the center console with switch unit. The original switch bag can be omitted or reused as desired. (Picture 17, 18)



If you have any questions or problems, please be sure to contact us, we look forward to your feedback to improve our products.





RACE THE  
ORIGINAL



Alte Bottroper Strasse 103  
D-45356 Essen  
0049. 201. 8 777 802  
service@cae-racing.de

[WWW.CAE-RACING.DE](http://WWW.CAE-RACING.DE)